

FREE REIN FOR IDEAS. Thanks to laser cutting, the design of the e700w can be fully adapted to the customer's corporate image and communication needs.

This model is equipped with a 19" display with or without touch interface, which can be combined with a keyboard or POS module if a payment system needs to be integrated.

The e700w can integrate a wide variety of peripherals without compromising its aesthetics: keyboard, ticket printer, pinpad, digital signature, game or webcam.

It can be customised in any colour from the RAL range and/or with cut vinyl, digital image and fretwork to adapt it to the customer's corporate image.

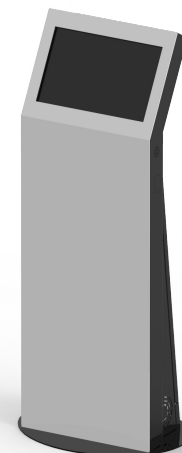

PROFILE PRODUCT

Manufacturer: Grupo EOS Ibérica.
Origin: Manufactured and assembled in Spain.

Production:
> 4 weeks (estimated time).
Material:
> 1.5 / 5 mm carbon steel sheet.
Flanges/internal fixings:
> Galvanised sheet metal.
Finish:
> High resistance epoxy paint.

Watertightness and sealing:
> IP53 (Optional).
Dimensions: > 1426 x 490 x 317 mm.
> 1426 x 490 x 317 mm.
Structural weight:
> 45 kg.
Use:
> Indoor.

STANDARD SPECIFICATIONS

Display:
> 24/7 industrial LCD.
Screen resolution:
> 19", 16:9 (wide / horizontal).
Number of screens:
> 1.
Video output:
> HDMI, DVI, SVGA.
Screen protection:
> 3+3 mm vandal-resistant glass.
Accesses:
> 1 door with security lock.
Connections:
> Internal terminal strip with I/O switch.

Structure colour Textured or plain.
Colour of the front RAL 9003/9007 plain.

OPTION COMPONENTS

Touch screen:
> IR 3 mm or capacitive 6 mm technology.
Fanless Industrial PC:
> Atom /Celeron/ i3/ i5/ i7.
Operating System:
> Android, Windows or Linux.
Multimedia:
> Speakers.
> WebCam
External Connections:
> RJ45/ IEC/ I/O switch / WiFi antenna.
Electrical panel:
> Terminal, circuit breaker and differential.
> Power supplies 5/12/24v.
Uninterruptible Power Supply System:
> 6 socket UPS.
Personalisation/Customisation:
> Cut vinyl/digital image.
> Airbrushing or multicolour graffiti.
> Industrial painting in various **RAL Colours**.

OPTIONAL ADAPTATIONS

Ticketing:
> 60 mm or 80 mm printer.
Readers:
> Barcode / QR.
> DNIe.
> RFID / NFC.
> USB / SD.
> Fingerprint reader.
Keyboard + Trackball module:
> IP65 vandal-proof extended keyboard.
Ingenico, Verifone or Hipercom POS module:
> Card reader + PinPad + Contactless.
Cooling system:
> Forced ventilation.
Customised front with fretwork:
> With or without LED backlighting.

VALUES PRODUCT

> Integration of a multitude of components.
> Vandal-proof protection.
> Robustness.
> Versatility in shapes and lettering and anagrams on the front.
> Large space for customising the front with colours, vinyls, digital image, etc.

ALTERNATIVE REFERENCES

> e600w.
> e700w Dual.
> e722w.
> e800.
> eService.
> eDirectorio.

SIZES PRODUCT AND VERSIONS PRODUCT

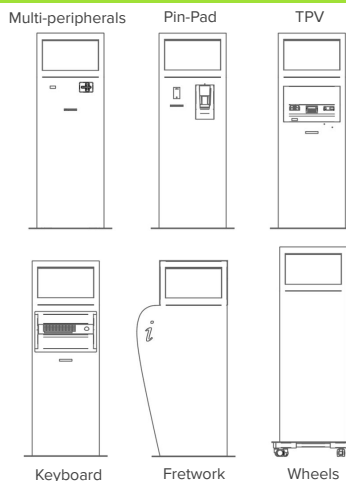
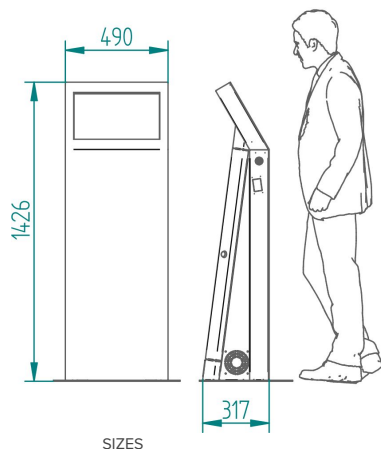

MOST COMMON APPLICATIONS

> Interactive information point.
> Ticketing.
> Queue management.
> Appointment management.
> Shift management.
> Ticket sales.
> Citizen cashier.
> Self-payment.
> POS.

MOST COMMON SECTORS

> Tourism, hotels and restaurants.
> Museums and libraries.
> Public administration (eGovernment, official bodies, corporations).
> Banking and insurance.
> Logistics and transport.
> Airports and seaports.
> Underground, train and bus stations.
> Trade fairs, congresses and exhibitions.

SUCCESS STORIES



DETAIL



SUCCESS STORIES



DETAIL

