



THE KEY IS OFTEN IN HOW THE MESSAGE IS DISPLAYED. The design of the e900, with its slightly sloping lines, makes this totem an ergonomic and innovative product.

It can integrate 43" screens vertically, and 22" screens horizontally. If the 22" horizontal display is chosen, it is possible to incorporate components such as ticket printers, webcams or RFID readers. The e900 is an effective communication tool, combining interactive information with backlit panels in A1 format.

The e900 can be custom configured. Its design and low cost make this structure ideal for removable solutions that only need to house a PC and an electronic component (such as an RFID or loyalty card, for applications connected to social networks). It also offers a large advertising space.



PROFILE PRODUCT

Manufacturer: Grupo EOS Ibérica
Origin: Manufactured and assembled in Spain.

Production:
 > 4 to 5 weeks (estimated time).

Material:
 > 2 to 4 mm carbon steel sheet.

Inner flanges:
 > Galvanised and/or PVC.

Finish:
 > High resistance epoxy paint.

Dimensions:
 1702x700x660mm.

Structural weight:
 70Kg.

STANDARD SPECIFICATIONS

Screen format
 > 43" in portrait.
Screen
 > LCD/LED Industrial Open Frame.
Video output
 > HDMI or SVGA.
Screen protection
 > 3+3 Vandal Resistant Glass.
Watertightness and sealing
 > IP42
Access
 > 1 door with security lock.
Connections
 > Internal terminal strip with I/O switch.

Structure colour: ● Embossing.

OPTIONAL COMPONENTS

Fanless Industrial PC
 > Atom / Celeron / i5.
Operating System
 > Windows or Linux.

External Connections
 > RJ45/IEC / I/O switch.

Protection strip
 > 6 outlets/15 min. UPS

Customisation
 > Cut vinyl/ Digital image.
Painting or Airbrushing
 > RAL colour customisation.

OPTIONAL ADAPTATIONS

Cooling system
 > Forced ventilation.

Communications
 > External Wifi antenna.

VALUES PRODUCT

- > Versatility in integrating LCD display formats and backlit panels.
- > Great visibility and space for customisation.
- > Integration of a multitude of components.
- > Ergonomics and design.
- > Vandal-proof protection.

ALTERNATIVE REFERENCES

- > eDirectorio.
- > eTotem.

SIZES PRODUCT AND VERSIONS PRODUCT

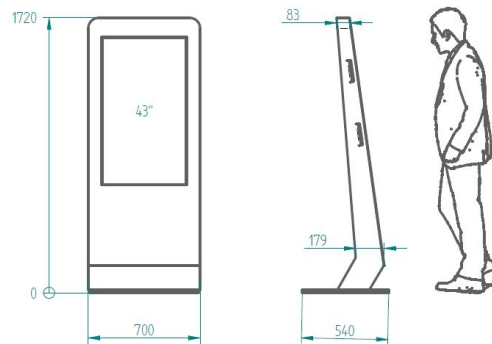

MOST COMMON APPLICATIONS

- > Indoor information point.
- > Industrial parks.
- > Directory of multi-purpose halls and cinemas.
- > Video-matón.
- > Digital Signage.
- > Gyms.
- > Shopping centres.

MOST COMMON SECTORS

- > Tourism, hotels and restaurants.
- > Museums and libraries.
- > Public administration (eGovernment, official bodies, corporations).
- > Banking and insurance.
- > Logistics and transport.
- > Sports and leisure (cinemas).
- > Electronic banking.
- > Communication, advertising and marketing.

SUCCESS STORIES

DETAIL

SUCCESS STORIES

DETAIL

