

Pad Kiosk Serie

Multimedia lectern

Customizable / Indoor



COMFORT IN PRESENTATIONS AND LECTURES. Without turning your head, with direct or remote control of the audiovisual media accompanying the speech.

The eAtril is a stand that can accommodate a 12" or 17" screen. In addition, a cover for the screen is included, in case you do not want to use it. Thus obtaining a stand for writing.

The loading of content is simple, by means of a multi-card/USB reader connected to the PC hidden in its base or to a control table. It offers space for two glasses, space for the presenter and support handles. It can be reused as many times as desired. It can be customised in any RAL colour and/or with cut vinyl, digital image and fretwork to adapt it to the client's corporate image.



PROFILE PRODUCT

Manufacturer: Grupo EOS Ibérica.
Origin: Manufactured and assembled in Spain.

Production:
 > 4 weeks (estimated time).

Material:
 > 1.5 / 5 mm carbon steel sheet.
 Flanges/Interior fastenings:
 > Galvanised sheet metal.

Finish:
 > High resistance epoxy paint.
 Watertightness and sealing:
 > IP42.

Dimensions:
 1114x722x482 mm.

Structural weight:
 30Kg.

Use:
 > Indoor.

STANDARD SPECIFICATIONS

Display:
 > Industrial LCD 24/7.

Screen resolution:
 > 12", 4:3 (horizontal).

Number of screens:
 > 1.

Video output:
 > HDMI, DVI, SVGA.

Screen protection:
 > Antivandalic glass 3+3 mm.

Accesses:
 > 1 door with security lock or latch.

Connections:
 > Internal terminal strip with I/O switch.

Colour of structure:
 > RAL: black / 9003/ 9007 plain.

OPTIONAL COMPONENTS

Touch screen:
 > IR 3mm or capacitive 6mm technology.

Fanless Industrial PC:
 > Atom /Celeron/ i3/ i5/ i7.

Operating System:
 > Android, Windows or Linux.

Multimedia:
 > Speakers.

External Connections:
 > RJ45/ IEC/ I/O Switch / WiFi Antenna.

Uninterruptible Power Supply:
 > 6-socket UPS.

Personalisation/Customisation:
 > Cut vinyl/ Digital image.
 > Airbrushing or multicolour graffiti.
 > Foam, dibond, makrolon or laminate.
 > Industrial painting in various **RAL Colours**.

OPTIONAL ADAPTATIONS

Additional screen:
 > 17" 4:3

Screen layout:
 > Vertical, to offer content to viewers (consult).
 > Screen cover.

Lighting:
 > Backlit front.
 > Lighting for the speaker.
 > Different LED colours.

VALUES PRODUCT

> Mobile and removable.
 > Reusable.
 > Protection for computer equipment.
 > Infinite options for customising the front in terms of shape and materials.
 > Easy design renewal and customisation.
 > Easy updating of contents.

SIZES PRODUCT AND VERSIONS PRODUCT

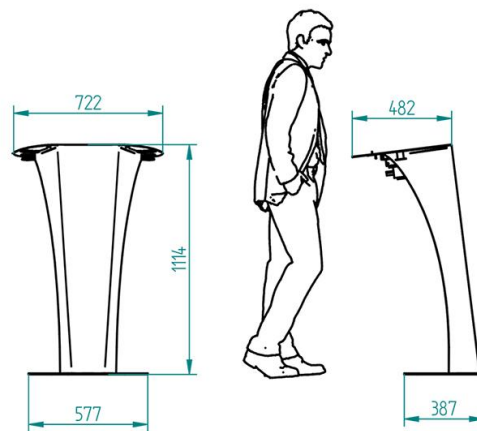

MOST COMMON APPLICATIONS

> Customer loyalty.
 > Brand or product presentations.
 > Political speeches.
 > Conferences and training presentations.
 > Scientific congresses.
 > Book or product presentations.
 > Art exhibitions and auctions.
 > Master classes.

ALTERNATIVE REFERENCES

> ePad Floor
 > eInfo.
 > eInfo Adaptado.

MOST COMMON SECTORS

> Communication, advertising and marketing.
 > Fairs, congresses and exhibitions.
 > Education and health.
 > Tourism, hotels and catering.
 > Museums and libraries.

SUCCESS STORIES

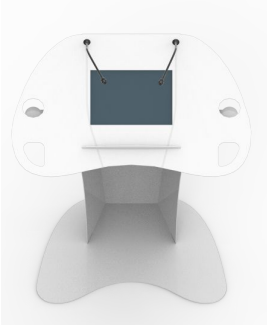

DETAIL

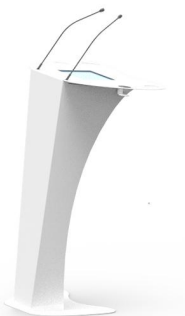

SUCCESS STORIES



DETAIL

