

Embedded Serie

Smart charging trolley for tablets and laptops

Customizable / Indoor



**STORES, STORES AND RECHARGES.** The smart charging cabinet is designed to hold 24 tablets or Chromebook laptops. While they are stored under lock and key, they are being recharged efficiently while taking up minimal space and with a single power socket.

The trolley has four wheels which allows it to be transported quite easily, allowing it to be used in several classrooms. It also has 2 doors, one at the front which gives access to load and store up to 24 iPads/Tablet or Laptops.

Available in any colour from the RAL range and can be adapted to the customer's brand image with vinyl or digital image. Standard colours are black for the body, white for the doors and blue for the load trays.



PROFILE PRODUCT

**Manufacturer:** Grupo EOS Ibérica.  
**Origin:** Manufactured and assembled in Spain.  
**Production:**  
 > 4 weeks (estimated time).  
**Material:**  
 > 1.5mm galvanised steel sheet.  
**Flanges/Interior fastenings:**  
 > Painted galvanised sheet steel.  
**Finish:**  
 > High resistance epoxy paint.  
**Dimensions:**  
 > 360x600x973 mm  
**Structure weight:**  
 > 70 Kg.  
**Use:**  
 > Indoor.

STANDARD SPECIFICATIONS

**Capacity:**  
 > 24 bays for Tablets/Chromebooks  
 > 3 shelves  
 > Injected plastic dividers  
**Divider dimensions:**  
 > Width 30mm, Depth 430mm, Height 273mm.  
**Cooling system:**  
 > 2 fans.  
**Accesses:**  
 > 2 doors with lock, 2 keys.  
**Connections:**  
 > Internal power strip with I/O switch.  
 > 3 m power cable.  
**Structure Colour:** ● RAL 9004 Black  
**Front Colour:** ○ RAL 9003 White  
**Colour inside:** ● RAL 5015 Blue

OPTIONAL COMPONENTS

**Handle:**  
 > Hand handle for easy movement.  
**Cooling system:**  
 > Extra ventilation.  
**External connections:**  
 > RJ45/ IEC/ I/O switch / EU, UK,US.  
 > Customised power cable.  
**Electrical panel:**  
 > Terminal, circuit breaker and differential.  
 > 5/12/24v power supplies.  
**Uninterruptible Power Supply System:**  
 > UPS with 6 outlets/15 min.

OPTIONAL ADAPTATIONS

**Size:**  
 > Load capacity.  
**Cooling system:**  
 > Forced ventilation.  
**Customised front with fretwork:**  
 > With or without led backlighting.  
**Personalisation/Customisation:**  
 > Cut vinyl/digital image.  
 > Airbrushing or multicolour graffiti.  
 > Industrial painting in various **RAL Colours**.

PRODUCT VALUES

> Reduced size.  
 > Safety and loading comfort.  
 > Vandal-proof protection.  
 > Easy to customise with digital image or cut vinyl.  
 > Configuration adaptable to needs.  
 > Transport of up to 200 units in a 40-foot container.

PRODUCT SIZES AND PRODUCT VERSIONS

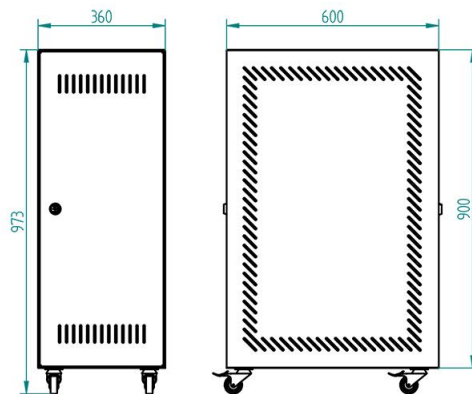

MOST COMMON APPLICATIONS

> Embedded Solutions.  
 > Information Point.  
 > Education.  
 > Hospitality.  
 > Betting centre.  
 > Catering.  
 > Recharging point.

ALTERNATIVE REFERENCES

MOST COMMON SECTORS

> Tourism, hotels and restaurants.  
 > Sports and leisure.  
 > Education and health.  
 > Logistics and transport.  
 > Museums and libraries.  
 > Public administration (e-administration, official bodies, corporations).  
 > Communication, advertising and marketing.

DETAIL

DETAIL

DETAIL

DETAIL

