

Panel PC Series

PC ATEX Panel

Industrial Components



Elevation

15" Industrial Touch Panel PC INTEL i3 1.8GHZ 6th generation with 6100u processor.

15" capacitive touch screen monitor and fanless computer in aluminium chassis, with fanless passive cooling system.

Certifications: CE / FCC Class A, ATEX Zone2 Ex nA ic IIC T4 Gc, Class I, Division2, Group ABCD T4, ANSI/ISA 12.12.01-2013, CSA Std. C22.2 No213-1987



Inside

TECHNICAL SPECIFICATIONS

Light Transmission(%): 90%.
Power Input: DC 9~36V.
Power Consumption: 27W.
Construction: 316 stainless steel chassis.
Mounting: VESA mount 100 x 100, Panel mount (option).
IP Rating Total: IP66.
Dimensions: 399 x 324 x 70 mm.
Net Weight: 9.7 kg.
Operating Temperature: -20~60°C.
Storage Temperature: -30~70°C.
Storage Humidity: 10 to 90% @ 40°C, non-condensing.
Safety: CSA C22.2 No.61010.
Certificate: CE / FCC Class A, ATEX Zone2 Ex nA ic IIC T4 Gc, Class I, Division2, Group ABCD T4, ANSI/ISA 12.12.01-2013, CSA Std. C22.2 No213-1987.

OTHER TECHNICAL DATA

CPU: Onboard 6th Gen Intel Core i3.
System Chipset: SoC.
Memory: 1 x 260-pin SO-DIMM up to 16GB DDR4 2400MHz.
USB: 1 x M12 8-pin for 2 x USB 2.0 with waterproof cover and chain.
Serial / Parallel: 1 x M12 8-pin for COM1, RS-232/422/485, default RS-232, with waterproof cover and chain.
LAN: 2 x M12 8-pin for LAN with waterproof cover and chain.
Graphics: 1 x M12 8-pin for VGA with waterproof cover and chain.
Power: 1 x M12 3-pin for DC power connector with waterproof cover and chain.
Storage: 1 x 2.5" HDD or SSD space, 1 x mSATA space.
Expansion Slot: 1 x Mini-PCIe (full size).
Display Type: 15" TFT-LCD.
Luminance (cd/m2): 450.
View Angle: 160(H)/150(V).
Contrast: 800:1
Backlight Lifetime: 50,000 hrs.
Touch: Projected Capacitive Touch.
Interface: USB.

I/O PORTS

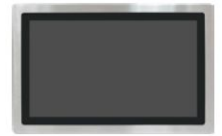

Front



Rear

CONECTIVIDAD WATERPROOF



MOUNTING SYSTEM



PRODUCT VALUES

- > Monitor 15" for explosive environments
- > Resistant to aggressive environments; dust, grease, vibrations.
- > Resistant to extreme temperatures and humidity.
- > Easy installation and assembly.
- > Expandable equipment in its configuration, up to 16GB of RAM memory.
- > Possibility of Wifi connection.
- > Low power consumption.

MOST COMMON APPLICATIONS

- > Hazardous environments.
- > HMI control panels.
- > Integration in electrical panels.
- > Industrial control systems (ICS).
- > Distributed control systems / SCADA.
- > Data acquisition systems (DAQs).
- > Assembly lines at factory level.
- > Mounting on transport vehicles.
- > Wireless station (Wifi/4G/GPS).
- > Outdoor advertising and Digital Signage.

SECTORS OF APPLICATION

- > Service stations.
- > Explosive environments.
- > Automatismos.
- > Aerospace.
- > Automotive.
- > Data Centers.
- > Distribution.
- > Naval sector.
- > Pharmaceutical Industry.
- > Transport and Logistics.
- > Transmission applications.

SOME SUCCESS STORIES

- > Meat industry
- > Shop-floor assembly
- > Solutions for agricultural engineering

ALTERNATIVE REFERENCES

- > eEX19 i3-6100u
- > eEX15 CL-N2930

CERTIFICATIONS



DIMENSIONS

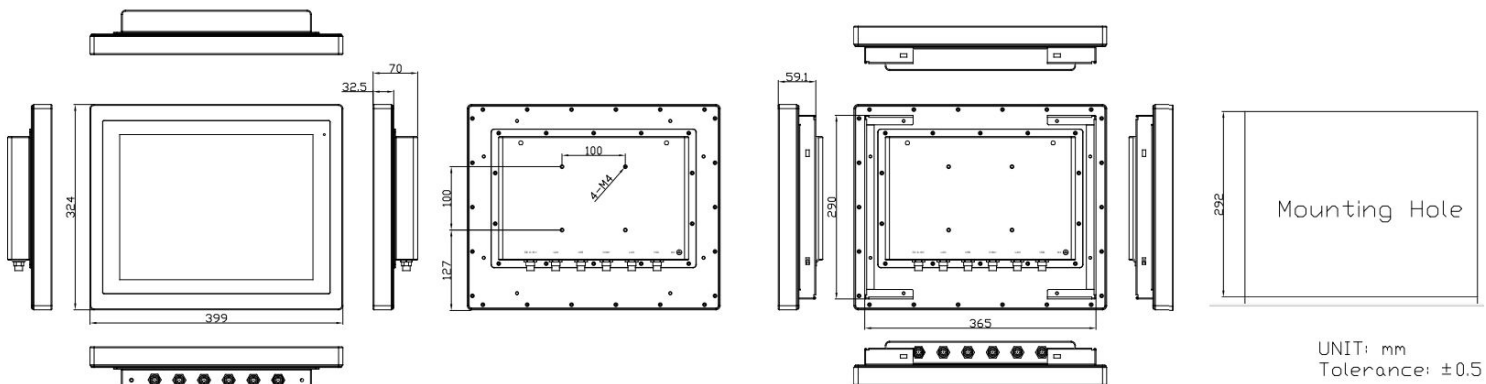

UNIT: mm
Tolerance: ±0.5