

AUTONOMOUS AND SHARED MANAGEMENT.

This POS has a wide versatility of use. It is designed to be used for autonomous or guided collection at the point of sale. On the other hand, it can be used as a consultation or loyalty system in which the customer can use it in an easy and simple way, saving time and without the intervention of personnel.

It is designed to be fixed to a counter or table. It has a USB output, to add different types of accessories; keyboard, barcode reader...

It can be customised in any RAL colour and/or with cut vinyl, digital image and fretwork to adapt it to the customer's corporate image. In addition, EOS Ibérica helps the customer to configure this POS by selecting the most suitable components: printer, QR code, identification or payment readers...



PROFILE PRODUCT

Manufacturer: Grupo EOS Ibérica.
Origin: Manufactured and assembled in Spain.

Production:
> 4 weeks (estimated time).
Material:
> 1.5 carbon steel sheet.
Inner flanges/fastenings:
> Galvanised sheet metal.
Finish:
> High resistance epoxy paint.
Watertightness and sealing:
> IP42.

Dimensions:
> 443x480x420 mm.
Structure weight:
> 10 kg approx.
Use:
> Indoor.

STANDARD SPECIFICATIONS

Display:
> 19" Industrial LCD.

Electronic Payment Module:
> Card reader,.
> QR reader, 80 mm printer, removable.
> Electronic ID reader.

Accesses:
> Rear door with ¼" latch.
> 4/6 sockets power strip.
> Easily accessible rear, unscrewable.
> Printer door access

Structure colour ● Textured or plain.

Colour of the front ○ ● RAL 9003/9007 plain

OPTIONAL COMPONENTS

Touch screen:
> IR 3mm or capacitive 6mm technology.
Fanless Industrial PC:
> Atom /Celeron/ i3/ i5/ i7.
Operating System:
> Android, Windows or Linux.
External Connections:
> RJ45/ IEC/ I/O switch/ WiFi antenna.
Electrical panel:
> Terminal block, circuit breaker and differential.
> Power supplies 5/12/24v.

Support:
> 4 rubber feet.

Personalisation/Customisation:
> Cut vinyl/digital image.
> Airbrushing or multicolour graffiti.
> Industrial painting in various **RAL Colours**.

OPTIONAL ADAPTATIONS

2nd Screen Module:
> eMonitor 12"
> eMonitor 17" > eMonitor 22
> eMonitor 22

Cooling system:
> Forced ventilation.

Lighting:
> Internal and/or external; for maintenance or corporate low draft in different colours.

VALUES PRODUCT

> Compact.
> Desktop.
> Large space to customise the front with colours, vinyls, digital image, etc.
> Loudspeakers.

SIZES PRODUCT AND VERSIONS PRODUCT

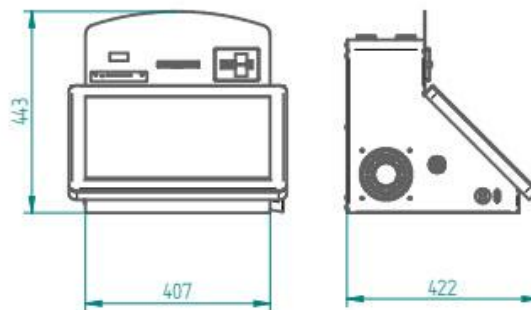

SIZES

MOST COMMON APPLICATIONS

> POS, payment terminals.
> Self-payment.
> Ticket sales.
> Citizen cash dispenser.
> Check-in for business reception.
> Loyalty
> Photo printing

ALTERNATIVE REFERENCES

> eCash
> eCash TPV

MOST COMMON SECTORS

> Tourism, hotels and restaurants.
> Pharmacies.
> Franchises.
> Supermarkets (Quick Checkout)
> Museums and libraries.
> Public administration.
> Clinics
> Photography and development

SUCCESS STORIES



DETAIL



SUCCESS STORIES



DETAIL

