

Xtrem serie

Large format outdoor LCD structure

Customizable / Outdoor

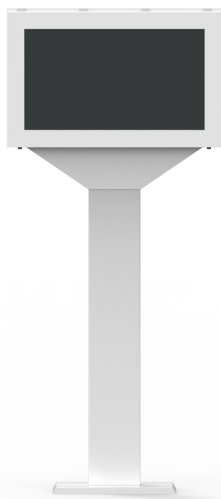

**DIGITAL SIGNAGE OR OUTDOOR ADVERTISING.** Tailor-made structure depending on your location and the size of the monitor.

Fully customisable configuration depending on your location and with the option of two-sided viewing. Available in four monitor sizes: 43", 49", 55" and 65". It is designed to work 24 hours a day, 365 days a year, withstands low and high temperatures (-40°C/+75°C) and is water resistant.

Like other Xtrem Series products, it is manufactured to IP65\* and IK10 specifications. It incorporates an intelligent air conditioning system that regulates the interior temperature and includes a low-reflection, high-transmission anti-vandal protection glass, an anti-fog system and anti-graffiti and anti-corrosion treatments. It also has an anchoring system to facilitate installation.



PRODUCT PROFILE

**Manufacturer:** Grupo EOS Ibérica.  
**Origin:** Manufactured and assembled in Spain.  
**Production:**  
 > 5 weeks (estimated time).  
**Material:**  
 > 2 / 5 mm carbon steel sheet.  
**Flanges/Inner fastenings:**  
 > Galvanised sheet metal.  
**Finish:**  
 > Textured high resistance epoxy paint.  
**Watertightness and sealing:**  
 > IP65\* (optional).  
**Dimensions**  
 to measure.  
**Structure weight**  
 70Kg.  
**Use:**  
 > Outdoor.

STANDARD SPECIFICATIONS

**Display:**  
 > 24/7 Industrial LCD.  
**Screen size:**  
 > 43"(horizontal) Touch  
 > 49" 55", 65" (horizontal) Non-touch  
**Number of screens:**  
 > 1.  
**Video output**  
 > HDMI, DVI, SVGA.  
**Screen protection**  
 > Antivandalic glass 3+3 mm.  
**Access**  
 > Security rear door with three points.  
**Connections**  
 > Internal terminal strip with I/O switch.  
**Structure**  
 > RAL: 9003/ 9007 plain.



OPTIONAL COMPONENTS

**Fanless Industrial PC:**  
 > Atom /Celeron/ i3/ i5/ i7.  
**Operating System:**  
 > Android, Windows or Linux.  
**Multimedia:**  
 > Speakers.  
**External Connections:**  
 > RJ45/ IEC/ I/O switch / WiFi antenna.  
**Electrical panel:**  
 > Terminal, circuit breaker and differential.  
 > Power supplies 5/12/24v.  
**Uninterruptible Power Supply System:**  
 > 6 socket UPS.  
**Personalisation/Customisation:**  
 > Cut vinyl/digital image.  
 > Airbrushing or multicolour Graffiti.  
 > Industrial paint in various **RAL Colours**.

OPTIONAL ADAPTATIONS

**Screen layout:**  
 > Horizontal.  
**Ticketing**  
 > Ticket printer 60 mm or 80 mm.  
 Readers  
 > Barcode / QR.  
 > DNle.  
 > RFID / NFC.  
 > USB / SD.  
**Ingenico,Verifone or Hipercom POS module.**  
 > Card reader + PinPad + Contactless.  
**Cooling system**  
 > Forced ventilation.

PRODUCT VALUES

> Watertight and vandal-proof product for outdoor use. IP65.  
 > High visibility at height and on both sides, double display.  
 > Intelligent temperature control system.  
 > Legible in sunlight, brightness adjusts automatically to the level of luminosity.  
 > High transmission glass and anti-reflective protection.

PRODUCT SIZES AND PRODUCT VERSIONS

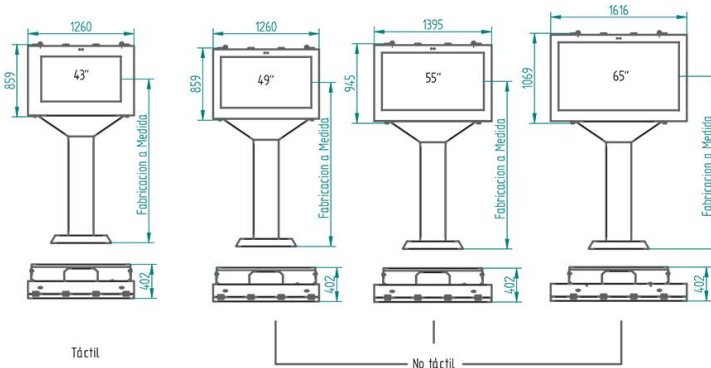

MOST COMMON APPLICATIONS

> Mobiliario urbano.  
 > Smartcity.  
 > Cartelería digital.  
 > Publicidad.

ALTERNATIVE REFERENCES

**Outdoor:**  
 > e1000.  
 > eTotem.  
 > eTotem Xtrem.  
 > eMonitor Xtrem.

MOST COMMON SECTORS

> Communication, advertising and marketing.  
 > Tourism, hotels and catering.  
 > Sports and leisure.  
 > Transport.  
 > Train, metro and bus stations.  
 > Airports and seaports.  
 > Industry.  
 > Public administrations.

SUCCESS STORIES

DETAIL

SUCCESS STORIES

DETAIL

